

Magneto-Peltier cooling of single-crystal $\text{Bi}_{1-X}\text{Sb}_X$ ($X = 0.12$ and 0.15) alloys

Osamu Yamashita · Kouji Satou · Shoichi Tomiyoshi

Received: 29 November 2004 / Accepted: 29 November 2005 / Published online: 28 November 2006
© Springer Science+Business Media, LLC 2006

Abstract The cooling temperatures of rectangular parallelepiped $\text{Bi}_{1-X}\text{Sb}_X$ ($X = 0.12$ and 0.15) single-crystals with the same thickness of $t = 2$ mm but different width W were measured at 113 K and 290 K as a function of electric current in the magnetic field B up to 2.17 T. The magnetic field was aligned along the thickness t of a sample and the current flows along its length L through the copper leads soldered to both end surfaces of cross section ($W \times t$), where W , t and L are parallel to the binary, bisector and trigonal axes of the single-crystal, respectively. The thermoelement was not in contact with a heat sink. The cooling temperature of $\text{Bi}_{0.85}\text{Sb}_{0.15}$ at 290 K was increased with an increase of B and was almost symmetric for the reverse of the field direction, while at 113 K it exhibited a maximum at $B = \pm 0.25$ T and a strong asymmetry for the field direction. The largest maximum cooling temperature ΔT_{max} of $\text{Bi}_{0.85}\text{Sb}_{0.15}$ was achieved when a thermoelement has optimum dimensions so that heat energy is hardly generated at the cold side. When the single-crystal $\text{Bi}_{0.85}\text{Sb}_{0.15}$ alloy has optimum dimensions of $L = 15$ mm, $W = 4$ mm and $t = 2$ mm, the ΔT_{max} at 290 K increased from 4.2 K in $B = 0$ T to 9.6 K in $B = +2.17$ T, so that it exceeded ΔT_{max} values of 5.7 K obtained for a typical Bi_2Te_3 and 8.5 K measured previously for Bi single-crystal in $B = +2.17$ T.

Introduction

Intrinsic Bi and Bi–Sb alloys have a transport property that is very sensitive to magnetic fields because of the presence of high-mobility electrons and holes in equal number, leading to the large magneto-resistance effect which results in a large increase in the Seebeck coefficient of pure Bi and Bi–Sb alloys in magnetic fields [1–4]. For this reason, Bi and Bi–Sb alloys have attracted much attention as an excellent thermomagnetic material. The effects of a magnetic field on the thermoelectric properties are referred to as the magneto-thermoelectric and thermomagnetic effects [5–7], which correspond to the magneto-Peltier (MP) and Ettingshausen (EH) effects, respectively. Similar to the ordinary thermoelectric devices, the energy conversion efficiency of a magneto-thermoelectric or a thermomagnetic device is also determined by the figure of merit ZT , given by $ZT = S^2T/\rho\kappa$, where S is the Seebeck coefficient, ρ the electrical resistivity, κ the thermal conductivity and T the absolute temperature.

The largest thermoelectric figures of merit occur in the Bi-riched Bi–Sb alloys along the trigonal axis at low temperatures, because the addition of Sb to Bi results in larger Seebeck coefficients and the alloying reduces the lattice thermal conductivity [8]. As a typical example of the MP effect, Wolfe and Smith [4] showed that the Z value of single-crystal $\text{Bi}_{0.88}\text{Sb}_{0.12}$ alloy reaches a maximum value of $5.8 \times 10^{-3}/\text{K}$ by the application of a transverse magnetic field of 1.7 T at 220 K. Shortly afterwards, Ertl et al. [9] showed using single-crystal $\text{Bi}_{0.93}\text{Sb}_{0.07}$ alloys that longer samples along the heat flow exhibit a greater Seebeck coefficient. After a while, Yim and Amith [8] reported that the single-crystal $\text{Bi}_{0.85}\text{Sb}_{0.15}$ alloy exhibits a

O. Yamashita (✉) · K. Satou · S. Tomiyoshi
Faculty of Engineering, Ehime University, Bunkyocho,
Matsuyama 790-8577, Japan
e-mail: yamashio@eng.ehime-u.ac.jp

surprisingly large magneto-thermoelectric figure of merit of $11.0 \times 10^{-3}/\text{K}$ in a transverse magnetic field of 0.3 T at a low temperature of 100 K. As for the EH effect, on the another hand, Cuff et al. [10] reported that by applying a magnetic field of 1 T, a single-crystal $\text{Bi}_{0.97}\text{Sb}_{0.03}$ alloy has a Z value of about $6 \times 10^{-3}/\text{K}$ at 100 K, which is twice as large as Bi_2Te_3 alloys.

In all of these experiments the magnetic field is applied parallel to the bisector axis of the crystal and the temperature gradient is applied parallel to the trigonal [4, 9, 11] or binary [10] axis. The largest Z value in these single-crystals occurs when the magnetic field is aligned along the bisector axis of the crystal and the electrical current passes along the trigonal axis. In addition, it has been reported by Yim and Amith [8] that the single-crystal $\text{Bi}_{0.85}\text{Sb}_{0.15}$ alloy exhibits the largest Z in the range between 80 K and 110 K, and at high temperatures the Bi-riched Bi–Sb alloy shows the largest Z .

Here it is important to bear in mind that there is a large difference between the MP and EH effects when we apply these effects to cooling devices. When we raise the cooling efficiency by use of the MP effect, the temperature gradient produced in a magnetic field is in the same direction as that of the primary electric current flow, similar to a Peltier device. In contrast, the temperature gradient developed by the EH effect is in a direction mutually perpendicular to the current flow and the applied field. As a practical application of the MP effect to a cooler, it has been reported by Yim and Amith [8] that Grouthamel constructed a cascaded Peltier-magneto-Peltier cooler consisted of eight stages using the p - and n -type bismuth-telluride compounds and n -type $\text{Bi}_{0.85}\text{Sb}_{0.15}$ alloy, and achieved a temperature as low as 128 K from room temperature while the hot side was kept at a temperature of 300 K. When applying the EH effect to a cooling device, the importance of the geometrical shape for a thermoelement was first indicated by O'Brien and Wallace [12]. Indeed, by using an ideally (exponentially) shaped Bi single-crystal, Harman et al. [13] obtained a large cooling of 101 K, from 302 K down to 201 K in a prohibitively large field of 10.99 T, while the hot side was maintained at 302 K. More recently, it was clarified experimentally by the present authors using the polycrystalline Bi and $\text{Bi}_{0.88}\text{Sb}_{0.12}$ [14, 15] and single-crystal Bi [16] that the geometrical shaping of a thermoelement is very important in an MP device and a combined MP and EH device, to achieve a large cooling temperature.

However, the geometrical contribution of a thermoelement to the cooling temperature has not yet been clarified for an MP device consisting of single-crystal

Bi–Sb alloys alone, although there were some experimental evidences [9, 17–19] for geometrical contribution to the Seebeck effect. To clarify the geometrical contribution to the cooling temperature, the present experiments for an MP cooling were intentionally performed on single-crystal $\text{Bi}_{1-X}\text{Sb}_X$ ($X = 0.12$ and 0.15) alloys shaped in a simple form and were carried out at 290 K in atmosphere and at 113 K in vacuum, not in contact with a heat sink.

The purpose of this study is to investigate the degree to which the geometrical shape and dimensions of single-crystal Bi–Sb alloys included in an MP device have an effect on the cooling temperature, and to examine by what factors the optimum dimensions suitable for cooling are determined and to confirm to what extent the cooling temperature of so shaped Bi–Sb alloys can exceed those of an optimized single-crystal Bi and of a typical p -type Bi_2Te_3 .

Experiments

Single-crystals of $\text{Bi}_{1-X}\text{Sb}_X$ ($X = 0.12$ and 0.15) alloys were prepared by the Bridgman method, using purer Bi and Sb granules of 99.99% as starting materials. The materials were weighed out in appropriate atomic ratios, charged into a quartz tube, and melted in an evacuated quartz tube by an induction heating to make a homogeneous melt without segregation. After melting, the alloys were unidirectionally solidified by the Bridgman method at a rate of 1.5 mm/h. A single-crystal Bi ingot and a hot-pressed p -type Bi_2Te_3 ingot were obtained from MaTeck Co., Ltd and Nihon Hatsujo Co., Ltd., respectively, where the grain size of the latter sample was approximately 20 μm . In order to investigate the thermoelectric properties of their ingots, they were cut into a parallelepiped of $5 \times 5 \times 15 \text{ mm}^3$ and a square plate of $10 \times 10 \times 2 \text{ mm}^3$, where the length of 15 mm and thickness of 3 mm were cut parallel to the trigonal axis in Bi–Sb and Bi single-crystals and perpendicular to the hot-pressed direction in Bi_2Te_3 . The former sample was subjected to Seebeck coefficient and electrical resistivity measurements (Sinku-Riko, Inc., Model ZEM-1). The latter sample was ground into a disk of $\phi 10 \times 2 \text{ mm}$ in order to measure its thermal conductivity using a laser-flash instrument (Sinku-Riko, Inc., Model TC-3000).

The Seebeck coefficient S was measured with an accuracy of 3% by the conventional technique, using alumel–chromel thermocouples for electrodes in the temperature range from 285 K to 378 K with the temperature difference of about 5 K. The electrical resistivity ρ was measured at 290 K concurrently by the

Table 1 Thermoelectric properties measured at 290 K for single-crystal Bi–Sb alloys, at 293 K for a single-crystal Bi and at 298 K for a polycrystalline *p*-type Bi₂Te₃, where ρ , S and κ of single crystal are measured along the trigonal axis

	Bi _{0.88} Sb _{0.12}	Bi _{0.85} Sb _{0.15}	Bi ^a	Bi ₂ Te ₃ ^b
Electrical resistivity ρ ($\mu\Omega\text{m}$)	1.43	1.45	1.37	12.6
Seebeck coefficient S ($\mu\text{V/K}$)	–86	–75	–107	225
Thermal conductivity κ (W/mK)	3.56	3.94	5.4	1.38
Figure of merit Z ($\times 10^{-3}/\text{K}$)	1.45	0.99	1.55	2.91

^a Ref. 16; ^b Ref. 15

four-probe method. The thermal conductivity κ was measured at 290 K. The thermoelectric properties of Bi–Sb, Bi and Bi₂Te₃ used here are listed in Table 1, all of which were measured along the direction of a length of 15 mm in single-crystal and the direction perpendicular to the hot-pressed direction in Bi₂Te₃.

The geometrical effects of a thermoelement in MP cooling were investigated by the following experimental methods. The single-crystal Bi–Sb ingots were cut into rectangular parallelepipeds with various widths, as given in Table 2, where a single-crystal Bi and a typical *p*-type Bi₂Te₃ were employed for comparing with the cooling temperatures of Bi–Sb alloys. A schematic diagram of magneto-Peltier cooling is shown in Fig. 1, where the length L , width W and thickness t of each sample are in the x , y and z directions, respectively. Copper current leads were soldered with Pb–Sn eutectic for Bi–Sb alloys, in the case of Bi [16], and attached with Ag-paste for Bi₂Te₃ to both end surfaces denoted by the shaded portions in Fig. 1. A uniform magnetic field B was applied in the $\pm z$ direction in the range from 0 T to 2.17 T at 290 K and in the range from 0 T to 1.25 T at 113 K. A direct current I flowing through the sample was varied in the range from 0.5 to 4.0 A at a step of 0.5 A in various magnetic fields, as shown in Fig. 2. In this manner, we can utilize the MP effect alone. At each current step, a constant current I was kept flowing for 20 s, whose time interval was sufficiently long for thermal equilibrium to be established. To make the heat capacitor of thermo-

couples as small as possible, thin copper–constantan thermocouples with a thickness of 0.1 mm were attached to copper leads at points P₁ and P₂ for each sample. The temperature was measured with an accuracy of 0.1 K. The sample was suspended by two copper leads but was not in contact with a heat sink. The present experiment, therefore, is neither adiabatic nor isothermal. The experiments of Bi–Sb single-crystals were carried out at 113 K in vacuum and 290 K in atmosphere. To investigate the geometrical effect of a thermoelement on the cooling temperature more practically, these experiments were made on Bi–Sb single-crystals shaped in a simple form which have the same thickness of $t = 2$ mm but different width W , where the width and thickness were parallel to the binary and bisector axes, respectively. The reason that such an experimental arrangement was employed is that the largest cooling temperature of these single-crystals is obtained when the magnetic field is aligned along the bisector axis of the crystal and electrical current passes along the trigonal axis [8]. In addition, the reason why the thickness t was not changed is that Bi single-crystal exhibited the largest cooling temperature at $t = 2$ mm [16]. Under such an experimental configuration, the top surface P₂ is heated and the bottom surface P₁ is cooled for an *n*-type material, while it is the reverse for a *p*-type material. Even when both the current and field directions were reversed, the cooling temperature itself did not change at all although the cold side changed places with the hot side.

The measurement of the apparent Seebeck coefficient S_a in the magnetic field was made in the following manner. When a temperature difference ΔT between points P₁ and P₂ reached about 6 K by passing the current through two copper leads, the current was switched off and immediately both the voltage ΔV between both ends and the temperature difference ΔT were measured concurrently by a digital voltmeter and two digital thermometers, respectively. The apparent S_a value was calculated from the relation $S_a = \Delta V/\Delta T$, where ΔT is about 6 K. The S_a value so obtained is not equivalent to the absolute S value obtained by the conventional technique, because the temperature

Table 2 Dimensions of single-crystal Bi–Sb alloys and a *p*-type Bi₂Te₃, where L , W and t of Bi are parallel to the trigonal, binary and bisector axes, respectively

Sample No.				L (mm)	W (mm)	t (mm)
Bi _{0.88} Sb _{0.12}	Bi _{0.85} Sb _{0.15}	Bi	Bi ₂ Te ₃			
1a	1b	–	–	15	2	2
2a	2b	–	–	15	3	2
3a	3b	–	–	15	4	2
4a	4b	–	–	15	6	2
–	–	5	–	15	4	2
–	–	–	6	12	4.8	4.8

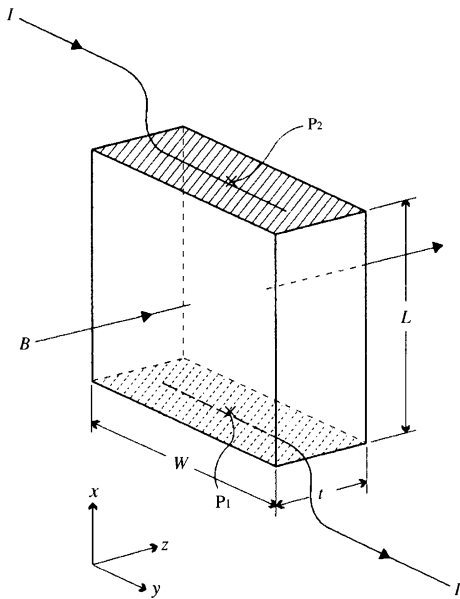

Fig. 1 Schematic diagram for a magneto-Peltier cooler

gradient generated by flowing the current in magnetic fields is inhomogeneous in a sample.

The electrical resistivity ρ in the magnetic field was measured by the four-probe method, using a digital voltmeter and a current generator. A low current of 100 mA was kept flowing for 1 s and was effective to control the temperature rise of a specimen, leading to the increase in ρ .

Results and discussion

Thermoelectric properties of Bi–Sb single-crystals

The thermoelectric properties of $\text{Bi}_{0.88}\text{Sb}_{0.12}$ and $\text{Bi}_{0.85}\text{Sb}_{0.15}$ single-crystals measured at 290 K along the trigonal axis were listed in Table 1, along with a single-crystal Bi and a polycrystalline *p*-type Bi_2Te_3 . Unlike pure Bi of a semimetal, Bi–Sb alloys used here are a

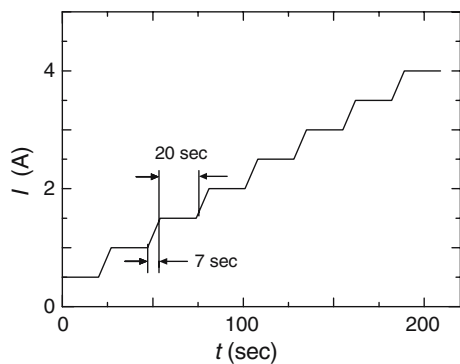

Fig. 2 Electrical current varied as step functions of time

semiconductor, which exhibits *n*-type conduction [20]. The Seebeck coefficients *S* and electrical resistivities ρ along the trigonal axis of Bi–Sb alloys coincided closely with those measured at 300 K by Yim and Amith [8] along the same axis of single-crystals with the corresponding compositions. The thermal conductivity κ along the trigonal axis of $\text{Bi}_{0.88}\text{Sb}_{0.12}$ agreed closely with the experimental value observed by Yim and Amith [8], but that of $\text{Bi}_{0.85}\text{Sb}_{0.15}$ was approximately 5% higher than their κ value. The figure of merit *Z* at 290 K reached $1.45 \times 10^{-3}/\text{K}$ for $\text{Bi}_{0.88}\text{Sb}_{0.12}$ and $0.99 \times 10^{-3}/\text{K}$ for $\text{Bi}_{0.85}\text{Sb}_{0.15}$, and the former value agreed with *Z* value obtained by Yim and Amith [8], but the latter one is approximately 5% lower than their *Z* value.

The electronic components κ_{el} of the thermal conductivity of Bi–Sb alloys at 290 K were calculated from the Wiedemann–Franz law $\kappa_{el} = L\sigma T$, where *L* is Lorentz number and $\sigma (=1/\rho)$ is the electrical conductivity. So estimated κ_{el} is 4.95 W/mK for $\text{Bi}_{0.88}\text{Sb}_{0.12}$ and 4.88 W/mK for $\text{Bi}_{0.85}\text{Sb}_{0.15}$, and interestingly their values were 39% and 24% higher than the experimental κ values, respectively, as listed Table 1, although the reason is not clear.

Maximum cooling temperature

The developed temperatures at points P_1 and P_2 on Bi–Sb single-crystals were measured as a function of current *I*, as shown in Fig. 3, where copper leads used here have a diameter of 0.8 mm. The diameter of a copper lead was chosen so as to give maximum cooling temperature at room temperature. The temperature T_1 at P_1 reached a minimum (T_{1min}) at a

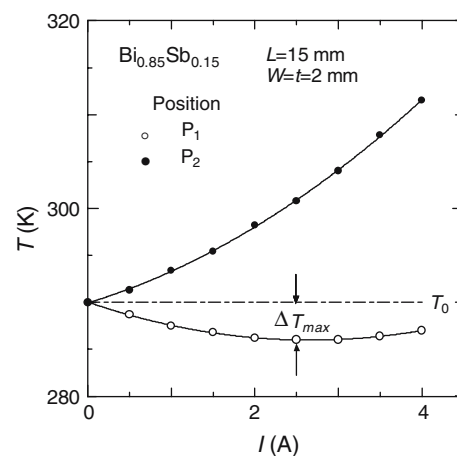

Fig. 3 Temperature measured at points P_1 and P_2 as a function of current *I* for $\text{Bi}_{0.85}\text{Sb}_{0.15}$ single-crystal (No.1b) using copper leads with a diameter of 0.8 mm, where P_1 and P_2 are located on cooled and heated surfaces, respectively

finite current, while the temperature T_2 at P_2 increased parabolically with increasing current I . The maximum cooling temperature ΔT_{\max} was defined as $\Delta T_{\max} = T_0 - T_{1\min}$, as shown in the figure, where T_0 is starting temperatures of 290 K for Bi–Sb single-crystals. The reason why the conventional temperature difference $\Delta T (=T_2 - T_1)$ was not employed here is that the ΔT values never saturate to a constant value, as long as the hot side is not maintained at a constant temperature. Here, one should bear in mind that the present ΔT_{\max} values become somewhat smaller than the actual values because of small heat flows along the copper leads or the thermocouples and a small amount of thermal radiation.

Magnetic field dependence of ρ and S_a of Bi–Sb single-crystals

Figure 4 shows the electrical resistivity ρ measured at 113 K and 290 K along the trigonal axis of the Bi–Sb

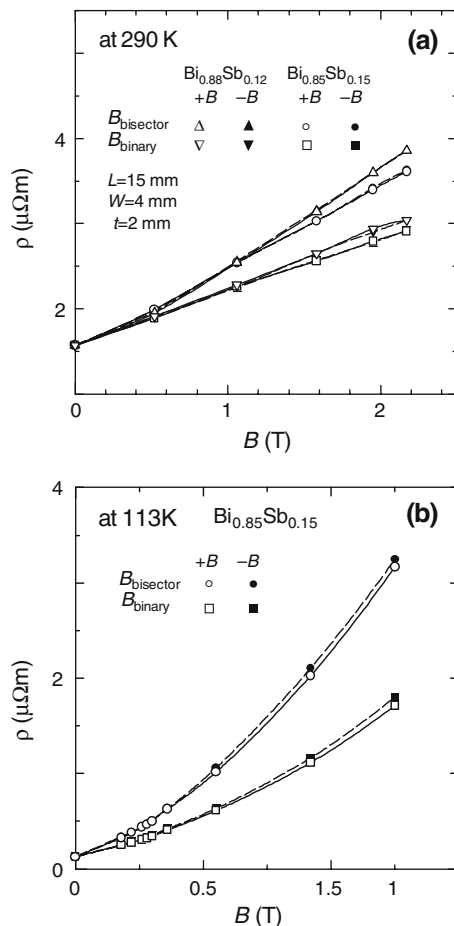

Fig. 4 Electrical resistivity ρ measured at 290 K (a) and 113 K (b) along the length L of $\text{Bi}_{0.88}\text{Sb}_{0.12}$ (No.3a) and $\text{Bi}_{0.85}\text{Sb}_{0.15}$ (No.3b) single-crystals with $L = 15$ mm, $W = 4$ mm and $t = 2$ mm, where L , W and t are parallel to the trigonal, binary and bisector axes, respectively

alloys (Nos.3a and 3b) when the magnetic field was applied along the bisector and binary axes of the single-crystal. The ρ values at 290 K increased monotonically with increasing the magnetic field owing to the transverse magneto-resistance effect and have larger values in the magnetic field applied along the bisector axis than the binary axis. When the field direction was reversed, however, the ρ values were little changed, in accordance with the result obtained by Abeles and Meiboom [21]. When a magnetic field of $B = +1.25$ T was applied along the binary and bisector axes of $\text{Bi}_{0.85}\text{Sb}_{0.15}$ alloy, the ρ values at 113 K were about 13.4 and 25.3 times larger than the zero field value, respectively, while in $B = +2.17$ T the ρ values at 290 K were about 1.85 and 2.30 times larger than the zero field value, respectively. The rate of increase in ρ due to the magnetic field depends strongly on both the temperature and the crystallographic direction. Similar results have been reported by Abeles and Meiboom [21].

Figure 5 shows the apparent Seebeck coefficient S_a measured at 113 K and 290 K along the trigonal axis of Bi–Sb alloys (Nos.3a and 3b) when the magnetic field was applied along the bisector and binary axes of the single-crystal. The apparent S_a values of Bi–Sb single-crystals in $B = 0$ T were in good agreement with the S values given in Table 1. The S_a of Bi–Sb alloys at 290 K increased monotonically with increasing the magnetic field. When a magnetic field of $B = +2.17$ T was applied along the bisector axis of $\text{Bi}_{0.88}\text{Sb}_{0.12}$ and $\text{Bi}_{0.85}\text{Sb}_{0.15}$ alloys, the S_a values at 290 K were about 1.47 and 1.63 times larger than the zero field value, respectively. The present rates of increase in S_a are close to 1.60 in Bi single-crystal. No significant difference in the present S values occurs at 290 K when the field direction was reversed. This is because the magnetic field was applied parallel to the bisector axis lying in a reflection plane of a crystal, so that the relation $S(+B) = S(-B)$ holds. This was verified experimentally by Wolfe and Smith [22] using Bi single-crystal. However, the dependence of S_a on the magnetic field for $\text{Bi}_{0.85}\text{Sb}_{0.15}$ at 113 K is quite different from that at 290 K and changed significantly when the field direction was reversed, as shown in Fig. 5(b), although the magnetic field is applied along the bisector direction. This phenomenon is known as the Umkehr effect, resulting in the relation $S(+B) \neq S(-B)$ [22]. Even when the field axis lies in a reflection plane of Bi single-crystal, however, a similar phenomenon has already been observed at 5.3 K. [23] Therefore, it may be related not to only the crystal symmetry of the field axis, but to some tilt of the electron or hole constant energy surfaces such as ellipsoids [24], with respect to

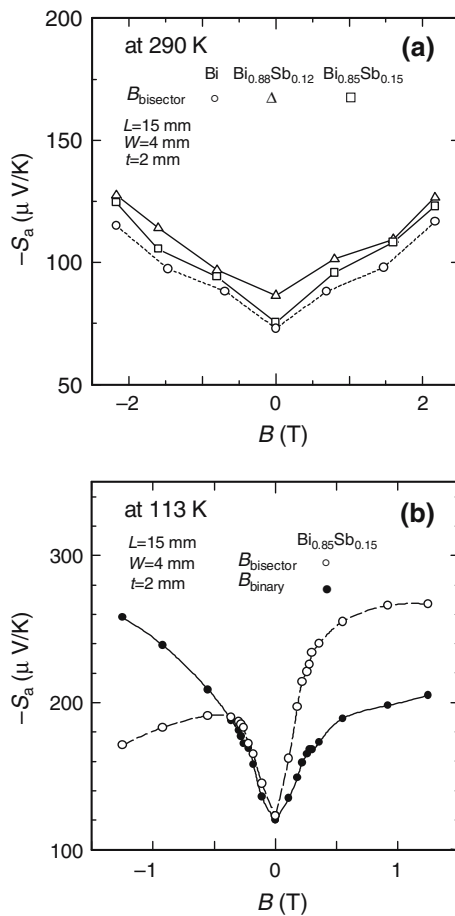

Fig. 5 Apparent Seebeck coefficient S_a measured at 290 K (a) and 113 K (b) as a function of magnetic field along the length L of $\text{Bi}_{0.88}\text{Sb}_{0.12}$ (No.3a) and $\text{Bi}_{0.85}\text{Sb}_{0.15}$ (No.3b) single-crystals, where L , W and t are parallel to the trigonal, binary and bisector axes, respectively

the field axis. This tilt angle of Bi and Bi–Sb alloys may change significantly with temperature and chemical composition and slightly with the preparation condition of the single-crystal, through the thermomagnetic effects.

Width dependence of a magneto-Peltier cooling

The ΔT_{max} values measured at 290 K in $B = 0$ and ± 2.17 T for Bi–Sb single-crystals are plotted as function of width W in Fig. 6, along with those of Bi single-crystal.

The ΔT_{max} values of $\text{Bi}_{0.88}\text{Sb}_{0.12}$ at 290 K have a local maximum at $W = 4\text{ mm}$ in $B = 0$ T and was enhanced strongly in $B = \pm 2.17$ T. The maximum value of $\text{Bi}_{0.88}\text{Sb}_{0.12}$ is 8.4 K at $W = 4\text{ mm}$ in $B = -2.17$ T, whose value is the same as that of Bi. The ΔT_{max} values of $\text{Bi}_{0.85}\text{Sb}_{0.15}$ at 290 K show a W dependence similar to that of $\text{Bi}_{0.88}\text{Sb}_{0.12}$, but its maximum value reached

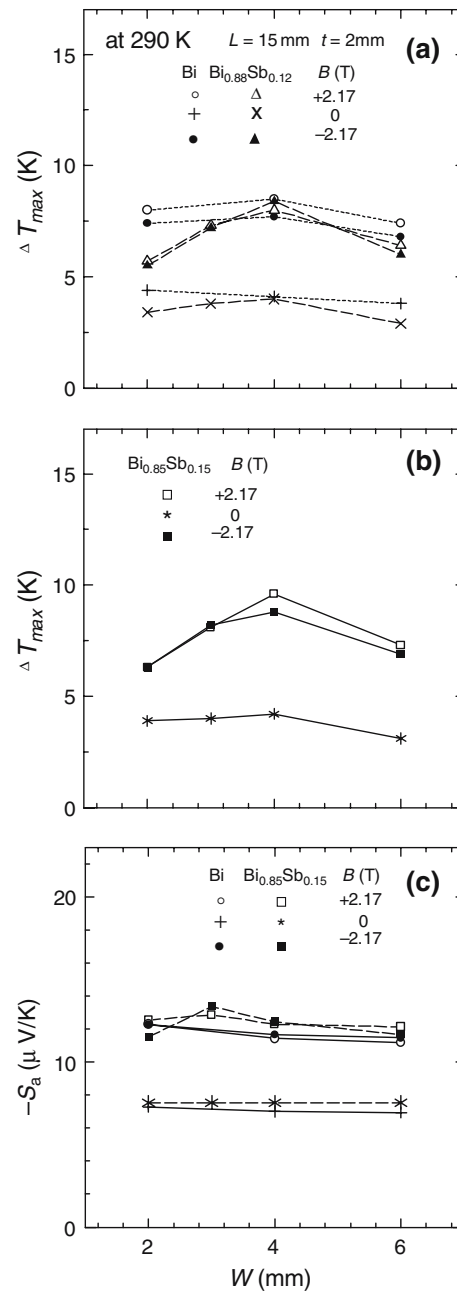

Fig. 6 Maximum cooling temperature ΔT_{max} and apparent Seebeck coefficient S_a at 290 K as a function of width W for $\text{Bi}_{0.88}\text{Sb}_{0.12}$ and $\text{Bi}_{0.85}\text{Sb}_{0.15}$ single-crystals with $L = 15\text{ mm}$ and $t = 2\text{ mm}$, where W , L and t are parallel to the binary, trigonal and bisector axes, respectively. The experimental data of a single-crystal Bi (No.5) was measured previously at 293 K (Ref. 16)

9.6 K at $W = 4\text{ mm}$ in $B = +2.17$ T, which is about 14% higher than those of Bi and $\text{Bi}_{0.88}\text{Sb}_{0.12}$. The dimensions of $\text{Bi}_{0.85}\text{Sb}_{0.15}$ (No.3b) giving a maximum ΔT_{max} is the same dimensions as Bi single-crystal (No.5). The strong dependence of the cooling temperature on W is expected to arise from the thermal

and electrical conduction, because the S_a values of $\text{Bi}_{0.85}\text{Sb}_{0.15}$ do not depend strongly on the width W , as shown in Fig. 6(c).

From the present experimental result, it was thus found that Bi and Bi–Sb alloys yield the maximum cooling temperature when these samples have a shape of $wt/L \doteq 0.5$ mm.

Optimum condition for the maximum cooling temperature

When a current I passes through a thermoelement placed in a magnetic field and the thermal gradient ($T_1 < T_2$) is produced at the cold and hot sides by the magneto-Peltier effect, in the simplest case the thermal rate equations for a thermoelement can be expressed as [20],

$$SIT_1 - I^2R/2 - K(T_2 - T_1) = -Q_1, \quad (1)$$

$$SIT_2 - I^2R/2 - K(T_2 - T_1) = +Q_2, \quad (2)$$

where S is the magneto-Seebeck coefficient, R ($=\rho L/wt$) the electrical resistance, K ($=\kappa wt/L$) the thermal conduction and Q_1 and Q_2 are heat energies generated at the cold and hot sides, respectively. The first, second and third terms in both equations represent the magneto-Peltier effect, Joule heating and thermal conduction, respectively.

We demonstrated experimentally in the previous paper [16] that the maximum cooling temperature of single-crystal Bi is achieved when the geometrical dimensions of a thermoelement satisfy $Q_1 = 0$. In the same manner as the previous paper, the Q_1 values were calculated for $\text{Bi}_{0.85}\text{Sb}_{0.15}$ single-crystals with various width in $B = 0$ and $+2.17$ T. Here, the electrical resistance R , thermal conduction K and Peltier-effect were calculated using the experimental data of ρ , κ and S and the dimensions which are listed in Tables 1 and 2 and shown in Figs. 4(a) and 6(c). Using so estimated R and K values, the Q_1 values were estimated for a current I and a temperature difference ($T_2 - T_1$) giving rise to the largest ΔT_{\max} value. Figure 7 shows the Q_1 values plotted as a function of width W for $\text{Bi}_{0.85}\text{Sb}_{0.15}$ single-crystals, along with Bi single-crystal. The Q_1 value of $\text{Bi}_{0.85}\text{Sb}_{0.15}$ in $B = 0$ T remains little changed in the range of 2–6 mm, while in $B = +2.17$ T it has a local maximum of -3.7 mW at $W = 4$ mm, which just corresponds to the width yielding the largest ΔT_{\max} value. This is consistent with the previous result that the maximum cooling temperature is achieved when Q_1 takes a value near zero, that is, no heat energy is generated at the cold side.

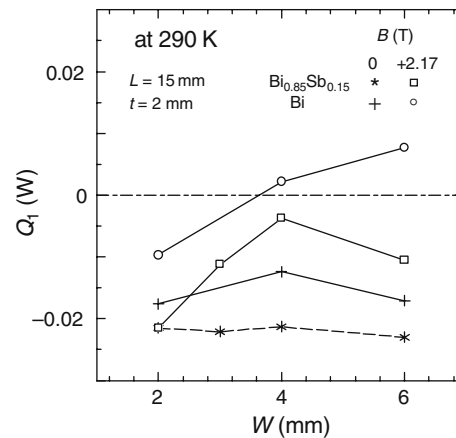

Fig. 7 Heat energy Q_1 ($=-SIT_1+I^2R/2+K(T_2 - T_1)$) as a function of width W for single-crystal $\text{Bi}_{0.85}\text{Sb}_{0.15}$ (No.3b), along with the previous experimental data of Bi (Ref. 16)

Dependence of ΔT_{\max} of $\text{Bi}_{0.85}\text{Sb}_{0.15}$ and Bi single-crystals and Bi_2Te_3 on magnetic field

Figure 8(a) shows the ΔT_{\max} values as a function of magnetic field for a single-crystal $\text{Bi}_{0.85}\text{Sb}_{0.15}$ (No.3b), a single-crystal Bi (No.5) and a polycrystalline Bi_2Te_3 (No.6). The ΔT_{\max} values for $\text{Bi}_{0.85}\text{Sb}_{0.15}$ and Bi increase monotonically with increasing the magnetic field and reached the maximum values at $B = +2.17$ T, while the values measured at 298 K for a p -type Bi_2Te_3 exhibit only small changes in magnetic fields in which the cooling temperature becomes slightly higher at $B = +1.4$ T than the zero field value. Here, the comparison between the cooling temperatures of the materials with the different types of conduction would be permitted, because the difference in the type of conductivity merely results in the replacement of the hot and cold sides and has no any influence on the cooling effect. As a matter of course, the grain size (approximately 20 μm) of Bi_2Te_3 would hardly affect the cooling temperature, because there is only a little magneto-Peltier effect in Bi_2Te_3 .

The Q_1 value for a typical p -type Bi_2Te_3 used here was -63.3 mW in the absence of magnetic field, whose value is much larger in absolute value than -3.7 mW for $\text{Bi}_{0.85}\text{Sb}_{0.15}$ of $W = 4$ mm and $+2.2$ mW for Bi single-crystal in a magnetic field of 2.17 T. The larger value Q_1 in absolute value results in smaller cooling temperatures, as mentioned above. Such a large Q_1 value of Bi_2Te_3 may make the ΔT_{\max} somewhat smaller than the actual temperatures. Although there are significant differences between their Q_1 values, the ΔT_{\max} values of the present specimens were compared with those of Bi and Bi_2Te_3 . The ΔT_{\max} for $\text{Bi}_{0.85}\text{Sb}_{0.15}$ was higher than that for Bi in the magnetic fields up to

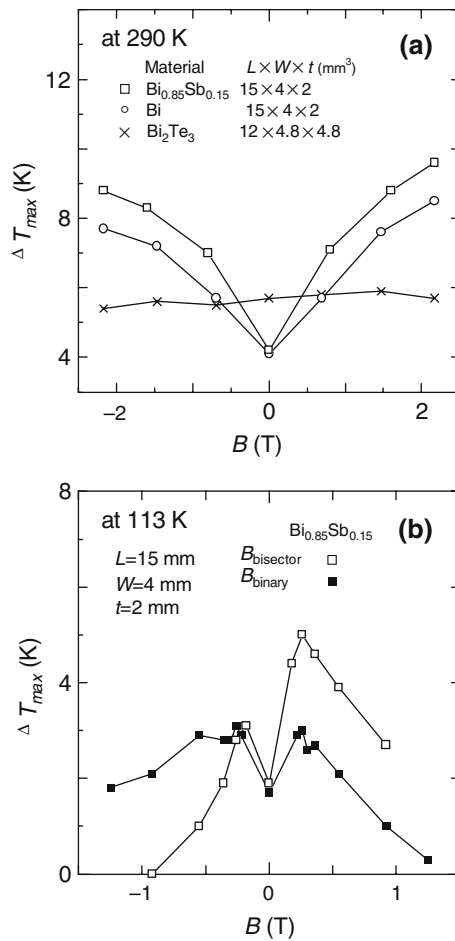

Fig. 8 Maximum cooling temperature ΔT_{\max} measured at 290 K (a) and 113 K (b) as a function of magnetic field for Bi_{0.85}Sb_{0.15} single-crystal with $L = 15$ mm, $W = 4$ mm and $t = 2$ mm, where L , W and t are parallel to the trigonal, binary and bisector axes, respectively. The experimental data of a single-crystal Bi (No.5) (Ref. 16) and a polycrystalline p -type Bi₂Te₃ (No.6) (Ref. 15) were measured previously at 293 K and 298 K, respectively

± 2.17 T, and it crosses over that for Bi₂Te₃ at $B \approx \pm 0.5$ T and exhibited larger cooling temperatures than that for Bi₂Te₃ at further high magnetic fields. The largest ΔT_{\max} for single-crystal Bi_{0.85}Sb_{0.15} was 9.6 K at $B = +2.17$ T. The large cooling temperature of Bi_{0.85}Sb_{0.15} single-crystal, therefore, is attributed to both a greater magneto-thermoelectric figure of merit (ZT) and the geometrical effect.

Figure 8(b) shows the ΔT_{\max} values measured at 113 K as a function of magnetic field for Bi_{0.85}Sb_{0.15} single-crystal (No.3b). The ΔT_{\max} for Bi_{0.85}Sb_{0.15} at 113 K increase abruptly with increasing B until it reaches a maximum at $B = \pm 0.25$ T and then decrease with a further increase of B , regardless of the field direction. This field dependence of ΔT_{\max} is quite different from that at 290 K and exhibited a stronger asymmetry for the reverse of the field direction when

the magnetic field was applied to the bisector direction rather than to the binary direction. It may reflect the asymmetry of S_a for the reverse of the field direction, as shown in Fig. 5(b). The ΔT_{\max} at 113 K reached a maximum cooling temperature of 5.2 K at $B = +0.25$ T, whose field value is the same as that giving the maximum Z of Bi_{0.88}Sb_{0.12} [4], but they are much smaller than the expected value. This is because the copper leads have an extremely high thermal conductivity of 663 W/mK at 113 K and it acts to suppress a lowering of the cooling temperature of the cold end. When the hot end of a thermoelement was placed in contact with a heat sink, therefore, the ΔT_{\max} should be enhanced significantly.

From this result, it is considered that an MP cooler consisting of Bi–Sb single-crystals would operate efficiently in a low magnetic field of 0.25 T at a low temperature of approximately 100 K. It is fully possible to produce such a low magnetic field in a narrow gap of 2–3 mm corresponding to a thickness of a thermoelement by using several permanent magnets consisting of Nd–Fe–B alloy [25]. When a thermoelement consisting of Bi–Sb single-crystal with optimum dimensions was operated in low temperature range from 70 K to 200 K, therefore, the MP cooler would be expected to operate more efficiently than the conventional Bi₂Te₃ device. In any case, the utilization of the MP effect should result in a high-performance cooler having lower power dissipation as compared to the conventional Peltier device, because the electrical resistivity of Bi–Sb alloys is only about one tenth of that of Bi₂Te₃.

Summary

The present experimental results can be summarized as follows.

- (1) The maximum cooling temperatures at 290 K in a magneto-Peltier cooling device consisting of rectangular parallelepiped Bi–Sb single-crystals increase monotonously with increasing the magnetic field, as in the case of pure Bi, and depend strongly on the width dimension along the binary axis of single-crystal, particularly in a high magnetic field. It was clarified experimentally that the largest cooling temperature is achieved when a thermoelement has optimum dimensions so that no heat energy is generated at the cold side. The optimization of the dimensions for a thermoelement was found to be very important to achieve the large cooling temperature in a magneto-Peltier cooler.

- (2) The maximum cooling temperatures for $\text{Bi}_{0.85}\text{Sb}_{0.15}$ at 113 K increase abruptly with increasing the magnetic field until it reaches a maximum at $B = \pm 0.25$ T regardless of the field direction, and then decrease with a further increase of the magnetic field. The ΔT_{max} and S values at 113 K exhibited a strong asymmetry for the reverse of the field direction, although the magnetic field was applied along the bisector axis lying in a reflection plane of a crystal.
- (3) $\text{Bi}_{0.88}\text{Sb}_{0.12}$ and $\text{Bi}_{0.85}\text{Sb}_{0.15}$ single-crystals exhibited the maximum cooling temperature at dimensions of $L = 15$ mm, $W = 4$ mm and $t = 2$ mm, as in the case of Bi single-crystal. The ΔT_{max} of $\text{Bi}_{0.85}\text{Sb}_{0.15}$ alloy reached a large cooling temperature of 9.6 K in a magnetic field of +2.17 T, so that it exceeded maximum cooling temperatures of 5.7 K obtained for a typical Bi_2Te_3 and 8.5 K measured previously for single-crystal Bi in $B = +2.17$ T. It was thus found that Bi and Bi–Sb alloys yield the maximum cooling temperature when these samples have a shape of $wt/L0.5$ mm. The present MP cooler, therefore, would be expected to operate more efficiently than the conventional thermoelectric devices when operating at low temperatures below 200 K.

Acknowledgement The authors are indebted to T. Iwamoto and K. Ishimoto for assistance with the measurements.

References

1. Lenoir B, Scherrer H, Caillat T (2001) In: Tritt TM (ed) Recent trends in thermoelectric materials research I: semiconductors and semimetals. Academic, New York, vol 69, p 101
2. Freibert F, Darling TW, Migiori A, Trugman SA (2001) In: Tritt TM (ed) Recent trends in thermoelectric materials research II: semiconductors and semimetals. Academic, New York, 2001, vol 70, p 207
3. Abeles B, Meiboom S (1956) Phys Rev 101:544
4. Wolfe R, Smith GE (1962) Appl Phys Lett 1:5
5. Harman TC, Honig JM (1967) Thermoelectric and thermomagnetic effects and applications. McGraw-Hill, New York
6. Seeger K (1997) Semiconductor physics. Springer, Berlin, p 94
7. Jan JP (1957) In: Seitz F, Turnbull D (eds) Solid state physics. Academic Press, New York, vol 5, p 1
8. Yim WM, Amith A (1972) Solid State Electron 15:1141
9. Ertl ME, Pfister GR, Goldsmid HJ (1963) Br J Appl Phys 14:161
10. Cuff KF, Horst RB, Weaver JL, Hawkins SR, Kooi CF, Enslow M (1963) Appl Phys Lett 2:145
11. Tanuma S, Sakurai M (1995) J Adv Sci 7:1630
12. O'Brien BJ, Wallace CS (1958) J Appl Phys 20:1010
13. Harman TC, Honig JM, Fischler S, Paladino AE, Button MJ (1964) Appl Phys Lett 4:77
14. Yamashita O, Tomiyoshi S (2002) Jpn J Appl Phys 41:6032
15. Yamashita O, Tomiyoshi S (2002) J Appl Phys 92:3794
16. Yamashita O, Satou K, Tomiyoshi S (2004) J Appl Phys 95:8233
17. Heremans JP, Thrush CM, Morelli DT (2001) Phys Rev Lett 86:2098
18. Heremans JP, Thrush CM, Morelli DT (2001) Phys Rev B 65:035209
19. Harman TC (1960) Phys Rev 118:1541
20. Jain AL (1959) Phys Rev 114:1518
21. Abeles B, Meiboom S (1956) Phys Rev 101:544
22. Wolfe R, Smith GE (1963) Phys Rev 129:1086
23. Steele MC, Bakiskin J (1955) Phys Rev 98:359
24. Goldsmid HJ (1970) Phys Stat Sol (a) 1:7
25. Sagawa M, Fujimura S, Togawa N, Yamamoto H, Matsuura Y (1984) J Appl Phys 55:2083